

Parts List

Handpieces H.10 and H.10D

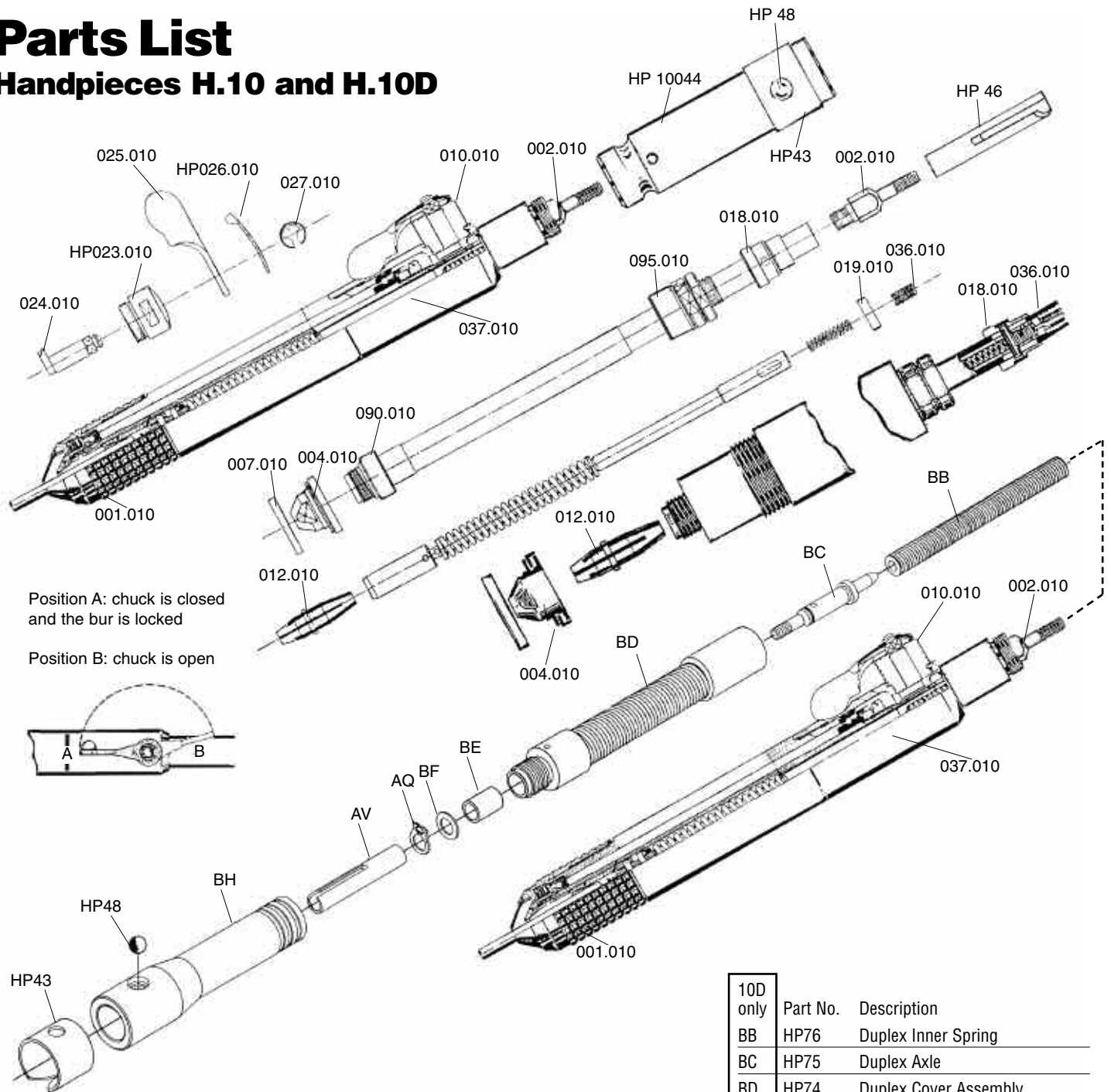

Position A: chuck is closed and the bur is locked

Position B: chuck is open

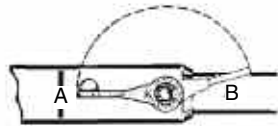

Part No.	Description
001.010	Nosepiece
001.014	3mm Collet
002.010	Adapter Screw
004.010	Chuck Nut
007.010	Nosepiece Spacer
010.010	Lever Assembly
012.010	3/32" Collet
013.010	Spindle
018.010	Tension Adjusting Sleeve
019.010	Pin
HP023.010	Cam Body
024.010	Cam
025.010	Lever
HP026.010	Lever Stay

Part No.	Description
027.010	Clip Ring
028.010	Adapter
029.010	Pin for 028.010
031.010	Inner Shaft
035.010	Spring
036.010	Adjusting Screw
037.010	Rear Housing
090.010	Front Bearing
095.010	Rear Bearing
201.010	1/8" (3.175mm) Collet
HP43	Catch Spring
HP46	Slotted Shaft Connector
HP48	Catch Ball
HP10044	Q.D. Sheath Connector

10D only	Part No.	Description
BB	HP76	Duplex Inner Spring
BC	HP75	Duplex Axle
BD	HP74	Duplex Cover Assembly
BE	HP51S	Sleeve Bearing
BF	HP47	Washer
AV	HP46	Slotted Shaft Connector
BH	HP42	Q.D. Sheath Connector
	HP48	Catch Ball
	HP43	Catch Spring

FOREDOM®

The Freedom Electric Company

16 Stony Hill Road, Bethel, CT 06801 USA

Phone: 203-792-8622 • Fax: 203-796-7861

www.freedom.net

E-mail: customerservice@blackstoneind.com